

4 3 2 1

REVISIONS					
ZONE	REV	DESCRIPTION	DATE	BY	APVD.
-	P1	PREPRODUCTION RELEASE	2/10/95	GDeR	-
-	A	PPRODUCTION RELEASE	4/25/95	GDeR	-
-	B	REVISED NOTE 5, ASSY No. 6555G-X WAS ASSY No. 5250L-XX-XXX	10/4/95	LP	

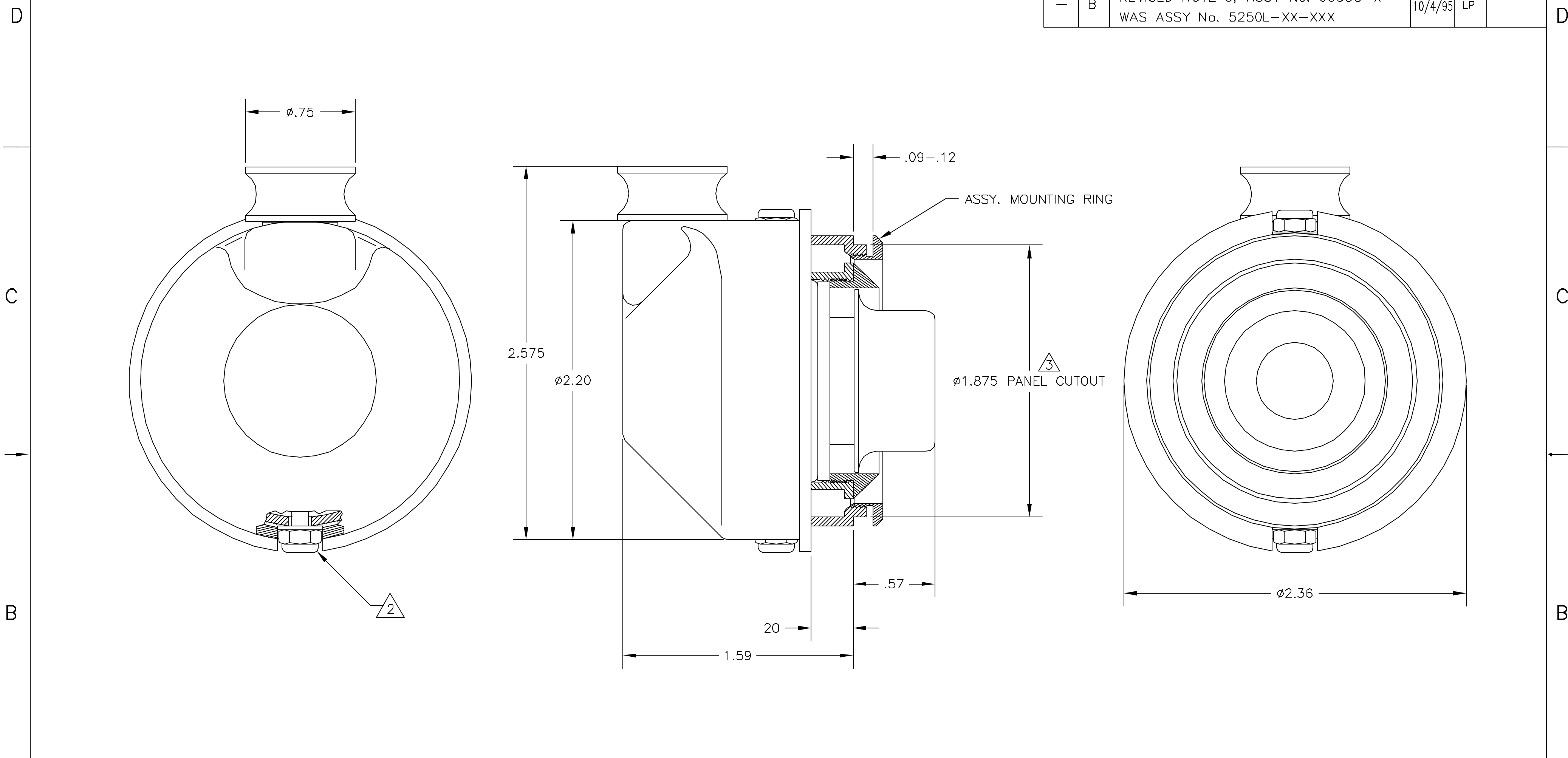

△ FINISH: REFER TO S.S.O. AND DWG. NO 274-100 & 274-101 FOR FINISH DASH NO. COMPLETE ASSY NO. IS 6555G-X.
FINISH

4. FEATURES: WEIGHT: 3.13 OZ

△ SIZE OF MOUNTING HOLE FOR FOR INTALLATION OF UNIT SHOULD BE $\phi 1.875 - \phi 1.895$.

△ TIGHTENING NUT - ADJUSTS FIRCTION OF SWIVEL. DO NOT TIGHTEN UNIT UNTIL IS INSTALL IN PANEL WITH MOUNTING RING.

1. FEATURES:

NOTES: UNLESS OTHERWISE SPECIFIED.

NEXT ASS'Y	USED ON
	THIS DOCUMENT CONTAINS PROPRIETARY INFORMATION EXCLUSIVE TO DPI LABS INC. AND SHALL NOT BE USED, DUPLICATED, OR DISCLOSED IN WHOLE OR IN PART FOR MANUFACTURE, PROCUREMENT, OR OTHER PURPOSES EXCEPT AS AUTHORIZED IN WRITING BY DPI LABS INC.

QTY	PART NO.	DESCRIPTION	SPECIFICATION	MATERIAL OR NOTE	ITEM
LIST OF MATERIALS					
UNLESS OTHERWISE SPECIFIED: DIMENSIONS ARE IN INCHES AND APPLY AFTER FINISH		APPROVALS	DATE		
TOLERANCES:		DRAWN	3/1/95		
XX ± .020		C. DeROBLES			
XXX ± .005		CHECKED			
ANGULAR ± 0' 30'		ENG. APPR.			
SURFACE FINISH		APPROVED		AIR GASPER, MR-11 MANUAL	
MAX. WEIGHT: GRAMS		APPROVED		SIZE	REV
				C	B
				CAGE NO.	DWG NO.
				ØNØX3	6555G
				SCALE	SHEET
				2/1	1 OF 1
				DO NOT SCALE DRAWING	REF. FILE NO.
					6555-01

4 3 2 1