

Features and Functions

- SmartLink-III™ System Interface
- Lightweight, modular design
- Built-in RF and IR handheld remote interface capabilities
- Built-in IR Teaching Interface via Provided PC Software
- Built-in PC compatible Serial Mouse Device and interface
- 100% compatibles with Philips' pronto RF series devices
- (2) separate IR Receiver/Repeater channels for maximum system flexibility
- Up to 6 IR repeating devices for 3rd-party devices control can be installed on each IR channel, for a total of 12 devices per module
- Firmware download capability

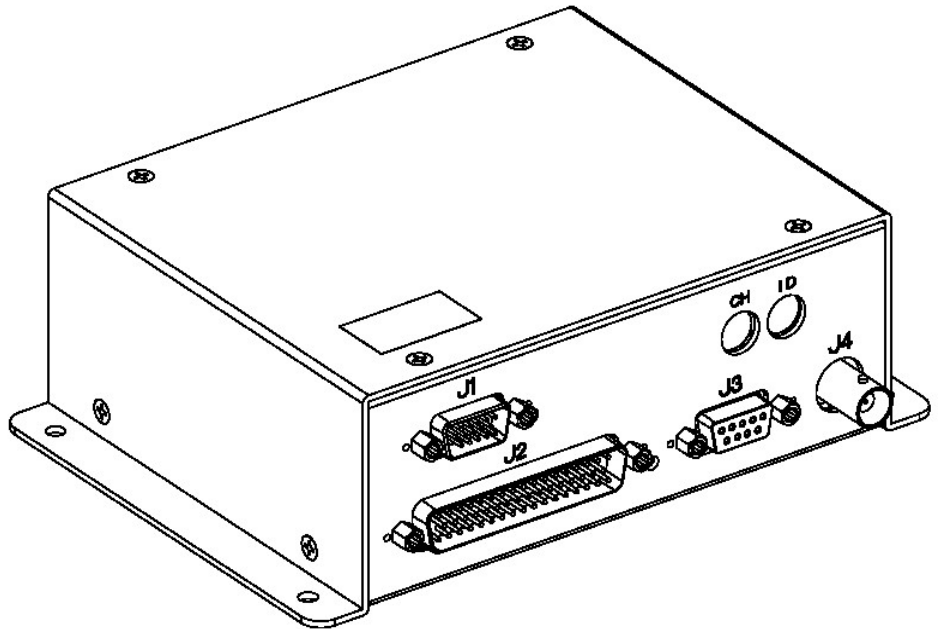

Description

This module controls infrared functions within an aircraft cabin. This module is integral part of several devices that make up the complete RF and infrared package. Our SL-1926, Advanced RF/IR Remote interface module allows one universal, RF, IR, or both hand-held remote control to be used to control a wide variety of consumer electronics and source equipment, plus any functions controlled by SmartLink-III™. Typically, customers use hand-held remote to manage entertainment systems, window shade masters, and cabin wash lighting. SmartLink-III™ will automatically update the status on any related switch panels and keep the system "in synch" when the remote is used. The module itself is very lightweight and compact, and can be easily installed within the tight confines of today's corporate aircraft, with a minimum of cable hook-ups required to connect the module into the SmartLink-III™ wire bus.

Application

- All Control applications requiring hand-held remote capabilities & integration with cabin management system via RF and/or IR
- At least one MS18201 IR Repeater required per IR channel and up to 3 could be wired in parallel for directional compensation (order separately)
- IR Retransmit device 282-00 required for 3rd party control (order separately)
- Programmer IR LED required for learnable handheld remote programming (order separately)
- RF Hand-held Remote unit i.e. Philips pronto may be use if RF link required.

Mechanical Specification

- All dimensions are in Inch
- Material 5052-H32 Aluminum
- Chem-Film Finish
- Weight 18 OZ

Electrical Specification

- **Operating Voltage:** 17 ~ 32 VDC
- **Operating Current:** 0.8 Amps
- **Operating Temperature:** -10 ~ +55 °C
- **System Interface:** SmartLink-III Compliant
Firmware Upload Re-configurable
- **Connector:** D-Sub Series with #4-40
Jackscrew ('P' suffix with Positronic's V5 Tab)
- **IR Repeat Channel:** 2
- **IR Repeat Carry Freq.:** 36 ~ 550 KHz
- **IR Repeat Port:** 6 per Channel
- **IR Repeat LED:** DPI P/N 282-00
- **IR Receive Interface:** DPI P/N MS18201, 3
Max per Channel
- **IR Program LED:** DPI P/N 276-143
- **RF Devices Interface:** Philips Pronto Series
- **RF Channel:** 4 Max.
- **RF Range Extension ID:** 16 Max.
- **RF Carry:** 418 MHz
- **RF Antenna Impedance:** 50/75 ohms
- **RF Antenna Length:** 6.7" in Quarter-Wave
- **Serial Mouse Port:** PC Compatible

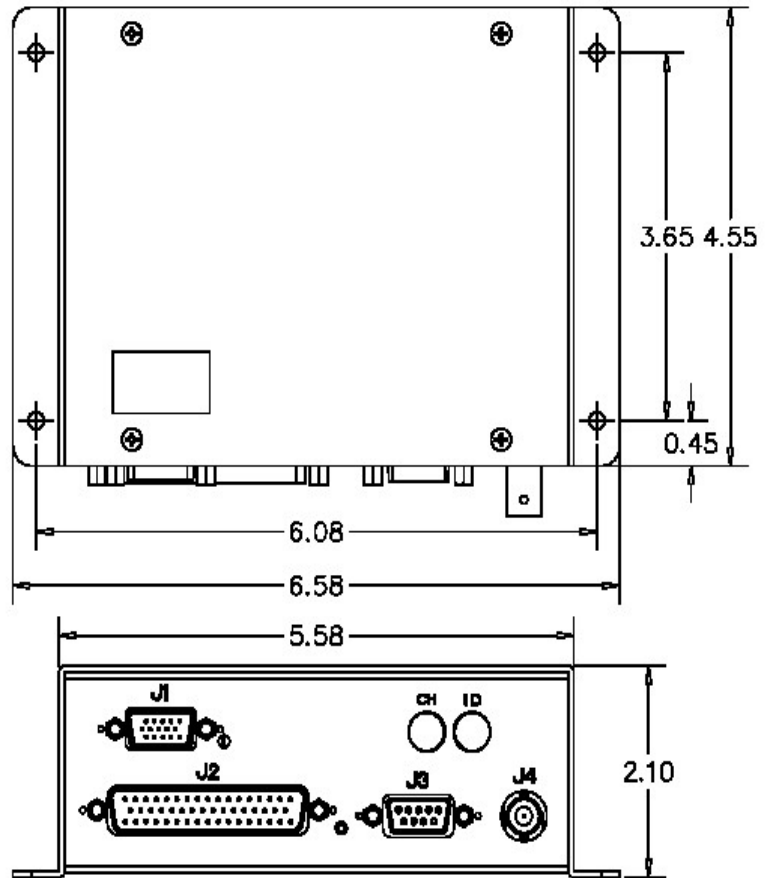

System Interconnect Connector

Label	Description	Connector Type
J1	SmartLink System Interface	High Density D-Sub 15 pin Plug (Male)
J2	Input /Output Interface Connector	D-Sub 50 pin Plug (Male)
J3	Serial Mouse Connector	D-Sub 9 pin Socket (Female)
J4	RF Antenna Connector	BNC Jack

Connector Pinouts

J1 D-Sub High Density 15 pin Plug (Male)

PIN	FUNCTION	PIN	FUNCTION	PIN	FUNCTION
1	Frame Ground	6	Device ID (HEX bit 0)	11	Device ID (HEX bit 3)
2	Power Input +28VDC	7	Device ID (HEX bit 1)	12	Device ID (HEX bit 4)
3	Power Return (GND)	8	Device ID Return (GND)	13	Device ID (HEX bit 5)
4	SmartLink Data bus – HI	9	SmartLink – Shield (GND)	14	Device ID (HEX bit 6)
5	SmartLink Data bus – LO	10	Device ID (HEX bit 2)	15	Device ID (HEX bit 7)

J2 D-Sub 50 pin Plug (Male)

PIN	FUNCTION	PIN	FUNCTION	PIN	FUNCTION
1	RESERVED	18	RESERVED	34	RESERVED
2	RESERVED	19	RESERVED	35	RESERVED
3	OPT A (RESERVED)	20	OPT B (RESERVED)	36	RESERVED
4	RS-232 PC INTERFACE RXD (TO PC TX)	21	RS-232 PC INTERFACE GND	37	RS-232 PC INTERFACE TXD (TO PC RX)
5	IR HANDHELD PROGRAM LED ANODE	22	IR REPEATER LED CATHODE #1-1 (GND)	38	RESERVED
6	REMOTE IR SENSOR GND #1	23	IR REPEATER LED CATHODE #1-2 (GND)	39	IR REPEATER LED ANODE #1-1
7	REMOTE IR SENSOR POWER #1	24	IR REPEATER LED CATHODE #1-3 (GND)	40	IR REPEATER LED ANODE #1-2
8	RESERVED	25	IR REPEATER LED CATHODE #1-4 (GND)	41	IR REPEATER LED ANODE #1-3
9	REMOTE IR SENSOR GND #2	26	IR REPEATER LED CATHODE #1-5 (GND)	42	IR REPEATER LED ANODE #1-4
10	REMOTE IR SENSOR POWER #2	27	IR REPEATER LED CATHODE #1-6 (GND)	43	IR REPEATER LED ANODE #1-5
11	RESERVED	28	IR REPEATER LED CATHODE #2-1 (GND)	44	IR REPEATER LED ANODE #1-6
12	REMOTE IR SENSOR DATA-LO #1	29	IR REPEATER LED CATHODE #2-2 (GND)	45	IR REPEATER LED ANODE #2-1
13	REMOTE IR SENSOR DATA-HI #1	30	IR REPEATER LED CATHODE #2-3 (GND)	46	IR REPEATER LED ANODE #2-2
14	REMOTE IR SENSOR DATA-LO #2	31	IR REPEATER LED CATHODE #2-4 (GND)	47	IR REPEATER LED ANODE #2-3
15	REMOTE IR SENSOR DATA-HI #2	32	IR REPEATER LED CATHODE #2-5 (GND)	48	IR REPEATER LED ANODE #2-4
16	RESERVED	33	IR REPEATER LED CATHODE #2-6 (GND)	49	IR REPEATER LED ANODE #2-5
17	RESERVED	-	-	50	IR REPEATER LED ANODE #2-6

J3 D-Sub 9 pin Socket (Female)

PIN	FUNCTION	PIN	FUNCTION
1	-	6	-
2	RxD	7	RTS
3	TxD	8	-
4	DTR	9	-
5	Signal Ground		

Installation Notes:

- FRAME GROUND: Chassis Ground connection using 20AWG hookup wire minimum.
- POWER INPUT AND POWER RETURN: Power Pins
- SL3 – HI/LO/SHLD: SmartLink-III™ bus connection, using 22AWG (minimum) Shielded Twisted Pair cable with single ended shield terminated to SHLD pin.

RF ANTENNA: Using RG174/RG179 (50/75 ohms) Coax, with maximum length of 40 feet, strip seven (7) inches of the Shield Braid from the end of the coax leaving the center conductor and insulated dielectric intact. Use Heat Shrink Tubing to cover any exposed Shield Braid. Ensure all metallic objects do not obscure stripped portion of the coax.