

Personal Video Switcher™ Video iPod™ Integration Made Simple!

Features & Benefits

*Allow iPod™
Integration onto
Local or Bulkhead
Monitors*

*No CMS
Modifications
Required*

*Maintain Privacy
of Personal Video*

*Includes Mating
RCA Panel with
Pre-Configured
Harness*

Introduction

The integration of iPod™ devices into CMS systems is not novel. Typically, this feature is provisioned into new entertainment configurations. However, the ability to integrate an iPod™ into an existing CMS can be difficult. First, the source must be wired into the A/V distribution system. Second, any upgrade to an existing CMS system requires modifications that the supplier must accommodate and communicate. An Engineering Change Order is usually the normal mode of business, plus the associated time, software/hardware lead times and cost. Thirdly, the new video source will not be private, unless software manipulated, and displayed on all monitors. Therefore, the personal video device is broadcasted throughout the entire cabin!



The Personal Video Switcher™ is a stand-alone solution. No cabin entertainment system modifications are required. This product allows a passenger to easily realize personal video on a designated bulkhead or local monitor. In addition, PA and Video briefer override capabilities are accommodated.

Simplicity – The Name of the Game!

This module interrupts the composite video signal into a monitor and replaces it with video from a personal video device. When video is detected at the personal input, it switches to this active source.

The core feature of this module is the automatic sync detection circuit. When video is detected at Video Input #2 (located on the J2 connector), the video switcher automatically engages Input #2. When no personal video is present or there is no power applied to the unit, it defaults to the CMS Video input.

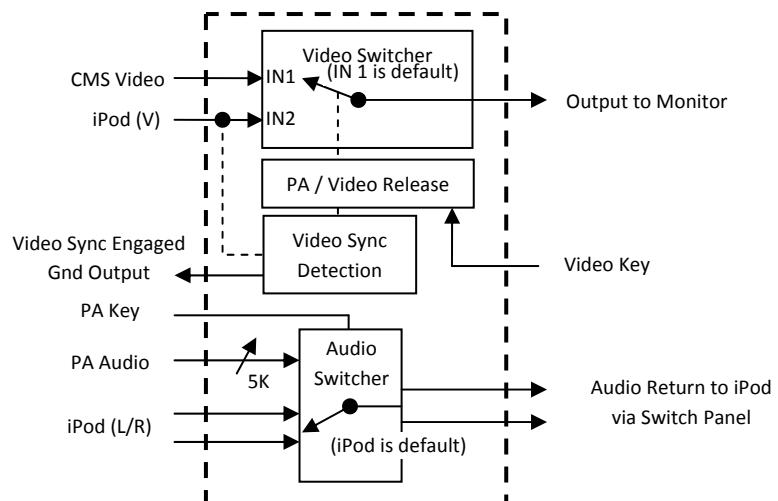

DPI Labs, Inc.
1350 Arrow Highway
La Verne, CA 91750
(909) 392-5777w
(909) 392-0277f
www.dpilabs.com

©2008 DPI Labs, Inc.
All Rights Reserved.

Copyright Notice

This information is copyrighted and is subject to change without notice.
It may be reproduced by permission of DPI Labs, Inc.

Personal Video Switcher™ Video iPod™ Integration Made Simple!



The module interfaces to a complimentary RCA mating switch panel, allowing audio, video and headphone interconnects for the passenger. The panel features a 24" pigtail that mates directly into J2 of the module. This panel is designed specifically to interface with the 5th generation and earlier iPod™ systems. These devices incorporate video output from the headphone jack. Therefore, this panel provides the headphone breakout.

Video sync detection is format independent. The iPod™ may output NTSC or PAL. Keep in mind that the output will be dependent upon which format the monitor is designed to accept. The video BNCs are isolated and switched differentially. The video ground of the CMS signal is passed through switcher. No termination impedance is induced by the module.

The PA Key allows headphone audio interruption. If desired the PA audio may override the iPod™ audio. An adjustment potentiometer provides gain control. The video may be interrupted if the Video Briefer Key is grounded independently or tied to the PA Key line. When the PA and Video Briefer controls are released, audio and video from the iPod™ will return if the video signal is still present.

Recommended Third-Party Interconnect Cables

This module is designed to accept any video source, despite its origin, allowing extreme flexibility. DPI recommends that manufacturer's cables and docking stations be used with specific devices to insure full compatibility. The following paragraphs qualify a typical Apple™ iPod™ installation.

5th Generation and Earlier iPods™. A headphone adapter cable (Figure 1) allows audio and video to be extracted from the headphone jack. Plug in the adapter cable from the iPod™ into the RCA panel. The iPod™ headphones plug directly into the RCA panel.

iPod™ Classic, iPhone™ and Video Nano™. The video connection is derived from the bottom connector. A 30-pin cable is required (Figure 2). The passenger connects the headphones to the iPod™ as normal. The cable plugs into the RCA adapter panel but only the video output is used. The headphone jack on the panel is not used.

Docking Stations. For docking station applications (Figure 3), the same 30-pin cable is used. Hardwire the video directly into J2 of the module and the RCA adapter panel is eliminated.

Charging Considerations. The 30-pin cable from Apple™ is available as a kit with an AC adapter for charging. Plug the supplied USB harness into the charging station for the charging option. As a note, when the iPod™ is used in the video output mode, the battery life is extended because backlighting is not required. As a result, a fully charged video iPod™ provides nearly 20 hours of video when used with an external monitor.

Contact Us!

If you are interested in this product and would like more information, please contact us at DPI Labs. We will be happy to assist you.



Figure 1



Figure 2



Figure 3

Copyright Notice

This information is copyrighted and is subject to change without notice.
It may be reproduced by permission of DPI Labs, Inc.